

# Control Integrated Power System (CIPOS™)

IKCS12F60AA

IKCS12F60AC

<http://www.lspst.com>



For Power Management  
Application

**LS** Power Semitech  
A joint venture with infineon



**Table of contents:**

<b>CIPOS™ Control Integrated POver System .....</b>	<b>4</b>
<b>Features .....</b>	<b>4</b>
<b>Target Applications .....</b>	<b>4</b>
<b>Description .....</b>	<b>4</b>
<b>System Configuration .....</b>	<b>4</b>
<b>Certification .....</b>	<b>4</b>
<b>Internal Electrical Schematic.....</b>	<b>5</b>
<b>Pin Assignment.....</b>	<b>6</b>
<b>Pin Description .....</b>	<b>6</b>
HIN1,2,3 and /LIN1,2,3 (Low side and high side control pins, Pin 15 - 20) .....	6
EN (enable, Pin 24) .....	7
ITRIP (Over-current detection function, Pin 21) .....	7
VDD, VSS (control side supply and reference, Pin 22, 23).....	7
VB1,2,3 and VS1,2,3 (High side supplies, Pin 1, 2, 4, 5, 7, 8).....	7
VRU, VRV, VRW (low side emitter, Pin 12, 13, 14) .....	7
V+ (positive bus input voltage, Pin 10).....	7
<b>Absolute Maximum Ratings .....</b>	<b>8</b>
<b>Module Section .....</b>	<b>8</b>
<b>IGBT and Diode Section.....</b>	<b>8</b>
<b>Control Section .....</b>	<b>9</b>
<b>Recommended Operation Conditions .....</b>	<b>9</b>
<b>Static Characteristics .....</b>	<b>10</b>
<b>Dynamic Characteristics.....</b>	<b>11</b>
<b>Integrated Components .....</b>	<b>12</b>
<b>Circuit of a Typical Application .....</b>	<b>12</b>
<b>Characteristics .....</b>	<b>13</b>
<b>Package Outline IKCS12F60AA.....</b>	<b>18</b>
<b>Package Outline IKCS12F60AC.....</b>	<b>19</b>

# CIPOS™ Control Integrated Power System

*Single In-Line Intelligent Power Module*

*3Φ-bridge 600V / 12A @ 25°C*

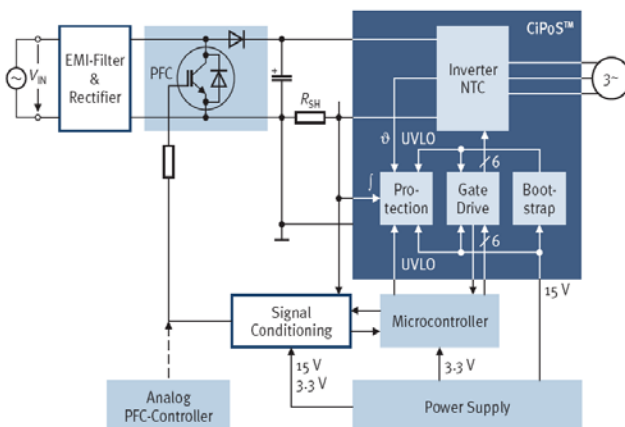


## Features

- Fully isolated Single In-Line molded module
- TrenchStop® IGBTs with lowest  $V_{CE(sat)}$
- Optimal adapted anti parallel diode for low EMI
- Integrated bootstrap diode and capacitor
- Rugged SOI gate driver technology with stability against transient and negative voltage
- Temperature monitor and over temperature shutdown
- Overcurrent shutdown
- Under voltage lockout at all channels
- Matched propagation delay for all channels
- Low side emitter pins accessible for all phase current monitoring (open emitter)
- Cross-conduction prevention
- Lead-free terminal plating; RoHS compliant
- Qualified according to JEDEC <sup>1</sup> (high temperature stress tests for 1000h) for target applications

## Target Applications

- Washing machines
- Consumer Fans and Consumer Compressors



## Description

The CIPOS™ module family offers the chance for integrating various power and control components to increase reliability, optimize PCB size and system costs.

This SIL-IPM is designed to control AC motors in variable speed drives for applications like air conditioning, compressors and washing machines. The package concept is specially adapted to power applications, which need extremely good thermal conduction and electrical isolation, but also EMI-save control and overload protection. The features of TrenchStop® IGBTs and anti parallel diodes are combined with a new optimized Infineon SOI gate driver for excellent electrical performance.

## System Configuration

- 3 half-bridges with TrenchStop® IGBT & FW-diodes
- 3Φ SOI gate driver
- Bootstrap diodes for high side supply
- Integrated 100nF bootstrap capacitance
- Temperature sensor, passive components for adaptations
- Isolated heatsink
- Creepage distance typ 3.2mm

## Certification

UL 1577 (UL file E314539)

<sup>1</sup> J-STD-020 and JESD-022



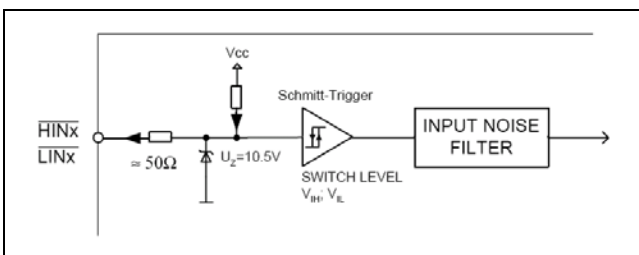
## Pin Assignment

Pin Number	Pin Name	Pin Description
1	VB3	high side floating IC supply voltage
2	W,VS3	motor output W, high side floating IC supply offset voltage
3	n.a.	None
4	VB2	high side floating IC supply voltage
5	V,VS2	motor output V, high side floating IC supply offset voltage
6	n.a.	None
7	VB1	high side floating IC supply voltage
8	U,VS1	motor output U, high side floating IC supply offset voltage
9	n.a.	None
10	V+	positive bus input voltage
11	n.a.	None
12	VRU	low side emitter
13	VRV	low side emitter
14	VRW	low side emitter
15	/HIN1	input gate driver high side 1/U
16	/HIN2	input gate driver high side 2/V
17	/HIN3	input gate driver high side 3/W
18	/LIN1	input gate driver low side 1/U
19	/LIN2	input gate driver low side 2/V
20	/LIN3	input gate driver low side 3/W
21	ITRIP	input overcurrent shutdown
22	VDD	module control supply
23	VSS	module negative supply
24	EN	input logic enable, output temperature monitoring

## Pin Description

### /HIN1,2,3 and /LIN1,2,3 (Low side and high side control pins, Pin 15 - 20)

These pins are active low and they are



**Figure 2: Input pin structure**

responsible for the control of the integrated IGBT.

The Schmitt-trigger input threshold of them are such to guarantee LSTTL and CMOS compatibility down to 3.3V controller outputs. Pull-up resistor of about 75kΩ is internally provided to pre-bias inputs during supply start-up and a zener clamp is provided for pin protection purposes. Input schmitt-trigger and noise filter provide beneficial noise rejection to short input pulses.

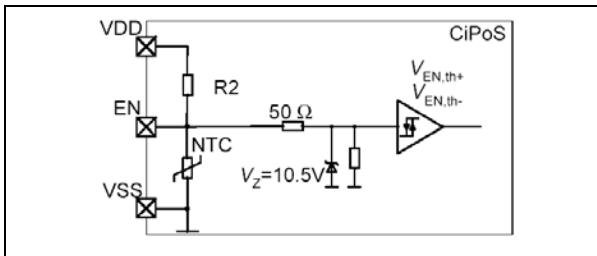
It is recommended for proper work of CIPOS™ not to provide input pulse-width lower than 1μs.

The integrated gate drive provides additionally a shoot through prevention capability which avoids the simultaneous on-state of two gate drivers of the same leg (i.e. HO1 and LO1, HO2 and LO2, HO3 and LO3).

A minimum deadtime insertion of typ 380ns is also provided, in order to reduce cross-conduction of the external power switches.

**EN (enable, Pin 24)**

The signal applied to pin EN controls directly the output stages. All outputs are set to LOW, if EN is at LOW logic level. The internal structure of the pin is the same as Figure 2 made exception of the switching levels of the Schmitt-Trigger, which are here  $V_{EN,TH+} = 2.1V$  and  $V_{EN,TH-} = 1.3V$ . The typical propagation delay time is  $t_{EN} = 900ns$ .



**Figure 3: Internal circuit at pin EN**

This pin may also be used for reading out the temperature close to the gate drive IC. Please refer to section “Integrated Components” for the specification of the integrated parts.

**ITRIP (Over-current detection function, Pin 21)**

CiPoS™ provides an over-current detection function by connecting the ITRIP input with the motor current feedback. The ITRIP comparator threshold (typ 0.46V) is referenced to VSS ground. A input noise filter prevents the driver to detect false over-current events.

Over-current detection generates a hard shut down of all outputs of the gate driver after the shutdown propagation delay of typically 900ns.

The fault-clear time is set to typically to 4.7ms.

**VDD, VSS (control side supply and reference, Pin 22, 23)**

VDD is the low side supply and it provides power both to input logic and to low side output power stage. Input logic is referenced to VSS ground as well as the under-voltage detection circuit.

The under-voltage circuit enables the device to operate at power on when a supply voltage of at least a typical voltage of  $V_{DDUV+} = 12.1V$  is at least present.

The IC shuts down all the gate drivers power outputs, when the VDD supply voltage is below  $V_{DDUV-} = 10.4V$ . This prevents the external power switches from critically low gate voltage levels during on-state and therefore from excessive power dissipation.

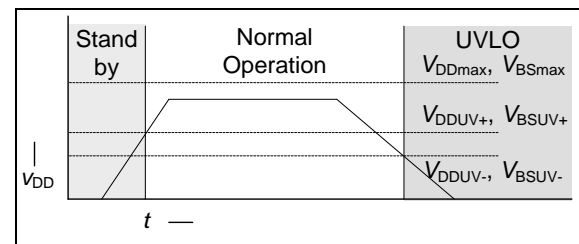
**VB1,2,3 and VS1,2,3 (High side supplies, Pin 1, 2, 4, 5, 7, 8)**

VB to VS is the high side supply voltage. The high side circuit can float with respect to VSS following the external high side power device emitter/source voltage.

Due to the low power consumption, the floating driver stage is supplied by an integrated bootstrap circuit connected to VDD. This includes also integrated bootstrap capacitors of 100nF at each floating supply, which are located very close to the gate drive circuit.

The under-voltage detection operates with a rising supply threshold of typical  $V_{BSUV+} = 12.1V$  and a falling threshold of  $V_{DDUV-} = 10.4V$  according to Figure 4.

VS1,2,3 provide a high robustness against negative voltage in respect of VSS of -50V. This ensures very stable designs even under rough conditions.



**Figure 4: Operation modes**

**VRU, VRV, VRW (low side emitter, Pin 12, 13, 14)**

The low side emitters are available for current measurements of each phase leg. It is recommended to keep the connection to pin VSS as short as possible in order to avoid unnecessary inductive voltage drops.

**V+ (positive bus input voltage, Pin 10)**

The high side IGBT are connected to the bus voltage. It is recommended, that the bus voltage does not exceed 500V.

## Absolute Maximum Ratings

( $T_J = 25^\circ\text{C}$ ,  $V_{DD} = 15\text{V}$  Unless Otherwise Specified):

### Module Section

Description	Condition	Symbol	Value		Unit
			Min	max	
Storage temperature range		$T_{\text{stg}}$	-40	125	$^\circ\text{C}$
Operating temperature control PCB <sup>1</sup>		$T_{\text{PCB}}$	-	125	$^\circ\text{C}$
Solder temperature	Wave soldering, 1.6mm (0.063in.) from case for 10s	$T_{\text{sol}}$	-	260	$^\circ\text{C}$
Insulation test voltage	RMS, $f=50\text{Hz}$ , $t=1\text{min}$	$V_{\text{ISOL}}$	2500	-	V
Mounting torque	M3 screw and washer	$M_S$	-	0.6	Nm
Mounting pressure on surface	Package flat on mounting surface	$N_{\text{MC}}$	-	150	N/mm <sup>2</sup>
Creepage distance		$d_S$	3.1	-	mm
External bootstrap capacitor	single capacitor charging, $V_{DD} = 15\text{V}$	$C_{\text{bs,ext}}$		19	$\mu\text{F}$

### IGBT and Diode Section

Description	Condition	Symbol	Value		Unit
			min	max	
Max. Blocking Voltage		$V_{\text{CES}}$	600	-	V
DC output current	$T_c = 25^\circ\text{C}, T_{\text{vj}} < 150^\circ\text{C}$ $T_c = 80^\circ\text{C}, T_{\text{vj}} < 150^\circ\text{C}$	$I_u, I_v, I_w$	-12 -6	12 6	A
Repetitive peak collector current	$I_p$ limited by $T_{\text{vjmax}}$	$I_u, I_v, I_w$	-18	18	A
Short circuit withstand time <sup>2</sup>	$V_{DD} = 15\text{V}, V_{\text{DC}} = 400\text{V},$ $T_{\text{vj}} = 150^\circ\text{C}$	$t_{\text{sc}}$	-	5	$\mu\text{s}$
IGBT reverse bias safe operating area (RBSOA)	$V_{DD} = 15\text{V}, V_{\text{DC}} \leq 500\text{V},$ $T_{\text{vj}} = 150^\circ\text{C}, I_c = 6\text{A}$ $V_{\text{CEmax}} = 600\text{V}$		Full Square		
Power dissipation per IGBT	$T_c = 25^\circ\text{C}$	$P_{\text{tot}}$	-	35	W
Operating junction temperature range	IGBT Diode	$T_{\text{vjI}}$ $T_{\text{vjD}}$	-40 -40	150 150	$^\circ\text{C}$

<sup>1</sup> Monitored by pin 24

<sup>2</sup> Allowed number of short circuits: <1000; time between short circuits: >1s.



Description	Condition	Symbol	Value		Unit
			min	max	
Single IGBT thermal resistance, junction-case		$R_{thJC}$	-	3.0	K/W
Single diode thermal resistance, junction-case		$R_{thJCD}$	-	4.2	

### Control Section

Description	Condition	Symbol	Value		Unit
			min	max	
Module supply voltage		$V_{DD}$	-1	20	V
High side floating supply voltage (VB vs. VS)		$V_{BS}$	-1	20	V
High side floating IC supply offset voltage	$t_p < 500ns$	$V_{S1,2,3}$	VDD-VBS-6 VDD-VBS-50	600	V
Input voltage	/LIN, /HIN, EN, ITRIP	$V_{in}$	-1	10	V
Operating junction temperature <sup>1</sup>		$T_{J,IC}$	-	125	°C
Max. switching frequency		$f_{PWM}$	-	20	kHz

### Recommended Operation Conditions

All voltages are absolute voltages referenced to  $V_{SS}$  -Potential unless otherwise specified.

Description	Symbol	Value		Unit
		min	max	
High side floating supply offset voltage	$V_S$	-3	500	V
High side floating supply voltage ( $V_B$ vs. $V_S$ )	$V_{BS}$	12.5	17.5	
Low side power supply	$V_{DD}$	12.5	17.5	
Logic input voltages LIN, HIN, ITRIP	$V_{IN}$	0	5	

<sup>1</sup> Monitored by pin 24

## Static Characteristics

( $T_c = 25^\circ\text{C}$ ,  $V_{DD} = 15\text{V}$ , if not stated otherwise)

Description	Condition	Symbol	Value			Unit
			min	typ	max	
Collector-Emitter blocking voltage	$V_{IN} = 5\text{V}$ , $I_C = 0.25\text{mA}$	$V_{(BR)CES}$	600	-	-	V
Collector-Emitter saturation voltage	$V_{DD} = 15\text{V}$ , $I_{out} = +/- 6\text{A}$ $25^\circ\text{C}$ $150^\circ\text{C}$	$V_{CE(sat)}$	- -	1.6 1.9	2.1 -	
Diode forward voltage	$V_{IN} = 5\text{V}$ , $I_{out} = +/- 6\text{A}$ $25^\circ\text{C}$ $150^\circ\text{C}$	$V_F$	- -	1.65 1.6	2.05 -	
Zero gate voltage collector current of IGBT	$V_{CE} = 600\text{V}$ , $V_{IN} = 5\text{V}$ $T_j = 25^\circ\text{C}$ $T_j = 150^\circ\text{C}$	$I_{CES}$	- -	- -	40 1000	$\mu\text{A}$
Short circuit collector current <sup>1</sup>	$V_{DD} = 15\text{V}$ , $t_{SC} \leq 5\mu\text{s}$ $V_{DC} = 400\text{V}$ , $T_{vj} = 150^\circ\text{C}$	$I_{C(SC)}^2$	-	40	-	A
Logic "0" input voltage (LIN,HIN)		$V_{IH}$	1.7	2.1	2.4	V
Logic "1" input voltage (LIN,HIN)		$V_{IL}$	0.7	0.9	1.1	V
EN positive going threshold		$V_{EN,TH+}$	1.9	2.1	2.3	V
EN negative going threshold		$V_{EN,TH-}$	1.1	1.3	1.5	V
ITRIP positive going threshold		$V_{IT,TH+}$	360	460	540	mV
ITRIP input hysteresis		$V_{IT,HYS}$	45	75	-	mV
$V_{DD}$ and $V_{BS}$ supply under voltage positive going threshold		$V_{DDUV+}$ $V_{BSUV+}$	11.0	12.1	12.8	V
$V_{DD}$ and $V_{BS}$ supply under voltage negative going threshold		$V_{DDUV-}$ $V_{BSUV-}$	9.5	10.4	11.0	V
$V_{CC}$ and $V_{BS}$ supply under voltage lockout hysteresis		$V_{DDUVH}$ $V_{BSUVH}$	1.2	1.7	-	V
Input clamp voltage (/HIN, /LIN, EN, ITRIP)	$I_{IN} = 4\text{mA}$	$V_{INCLAMP}$	9.0	10.1	13.0	V
Quiescent $V_{Bx}$ supply current ( $V_{Bx}$ only)	$V_{HIN} = \text{low}$	$I_{QB}$	-	360	550	$\mu\text{A}$
Quiescent $V_{DD}$ supply current ( $V_{DD}$ only)	$V_{IN} = \text{float}$	$I_{QDD}$	-	2.0	3.0	mA
Input bias current	$V_{IN} = 5\text{V}$	$I_{IN+}$	-	55	100	$\mu\text{A}$
Input bias current	$V_{IN} = 0\text{V}$	$I_{IN-}$	-	110	200	$\mu\text{A}$
ITRIP Input bias current	$V_{ITRIP} = 5\text{V}$	$I_{ITRIP+}$	-	75	120	$\mu\text{A}$
EN Input bias current	$V_{EN} = 5\text{V}$	$I_{EN+}$	-	180	300	$\mu\text{A}$
Leakage current of high side	$T_{j,IC} = 125^\circ\text{C}$ , $V_S = 600\text{V}$	$I_{LVS}^2$	-	30	-	$\mu\text{A}$

<sup>1</sup> Allowed number of short circuits: <1000; time between short circuits: >1s.

<sup>2</sup> Test is not subject of product test, verified by characterisation

## Dynamic Characteristics

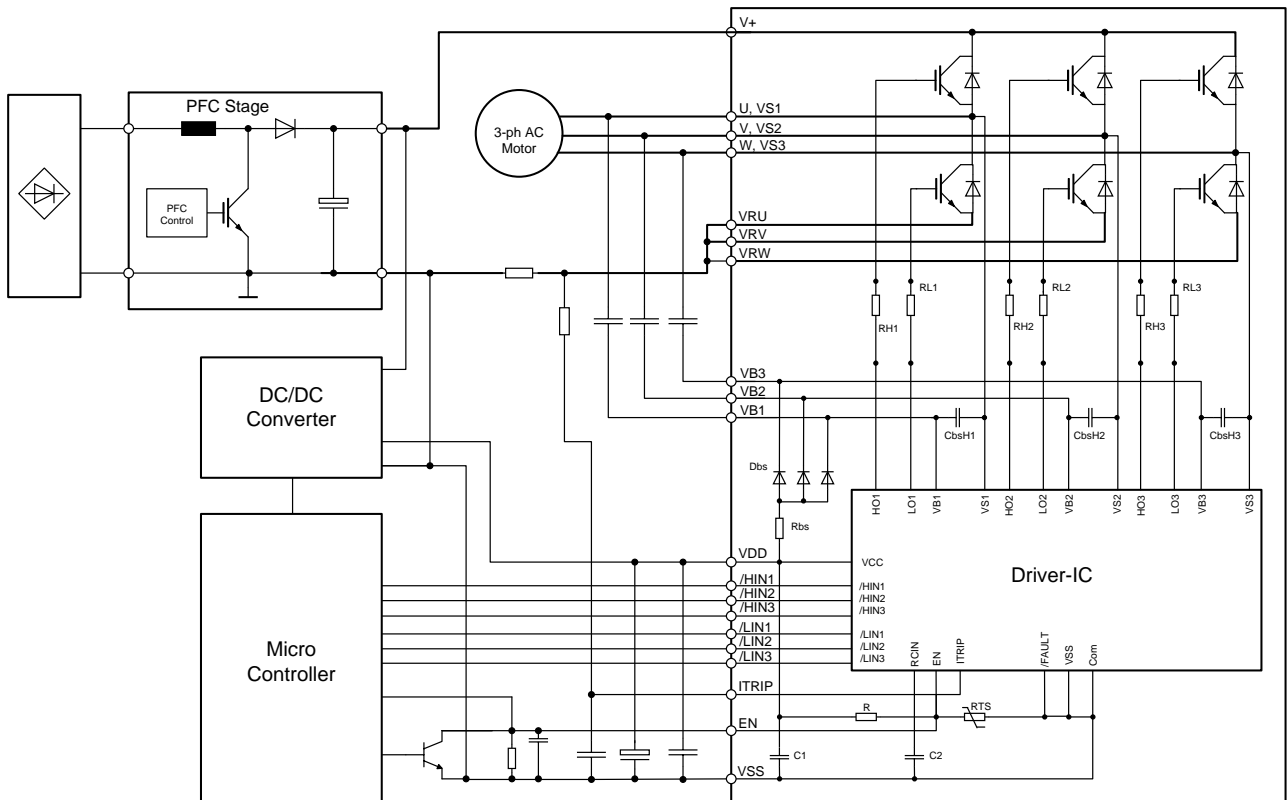
( $T_c = 25^\circ\text{C}$ ,  $V_{DD} = 15\text{V}$ , if not stated otherwise)

Description	Condition	Symbol	Value			Unit
			min	typ	max	
Turn-on propagation delay High side or low side	$V_{LIN,HIN} = 0\text{V}$ ; $I_{out} = 6\text{A}$ , $V_{DC} = 300\text{V}$	$t_{d(on)}$	-	617	-	ns
Turn-on rise time High side or low side	$I_{out} = 6\text{A}$ , $V_{DC} = 300\text{V}$ $V_{LIN,HIN} = 5\text{V}$	$t_r$	-	21	-	ns
Turn-off propagation delay High side or low side	$V_{LIN,HIN} = 5\text{V}$ ; $I_{out} = 6\text{A}$ , $V_{DC} = 300\text{V}$	$t_{d(off)}$	-	832	-	ns
Turn-off fall time High side or low side	$I_{out} = 6\text{A}$ , $V_{DC} = 300\text{V}$ $V_{LIN,HIN} = 0\text{V}$	$t_f$	-	29	-	ns
Shutdown propagation delay ENABLE	$V_{EN} = 0\text{V}$ , $I_u$ , $I_v$ , $I_w = 6\text{A}$	$t_{EN}$	-	900	-	ns
Shutdown propagation delay ITRIP	$V_{ITRIP} = 1\text{V}$ , $I_u$ , $I_v$ , $I_w = 6\text{A}$	$t_{ITRIP}$	-	900	-	ns
Input filter time ITRIP	$V_{ITRIP} = 1\text{V}$	$t_{ITRIPmin}$	155	210	380	ns
Input filter time at LIN for turn on and off and input filter time at HIN for turn on only	$V_{LIN,HIN} = 0\text{V} \& 5\text{V}$	$t_{FILIN}$	120	270	-	ns
Input filter time at HIN for turn off	$V_{HIN} = 5\text{V}$	$t_{FILIN1}$	-	220	-	ns
Input filter time at HIN for turn off	$V_{HIN} = 5\text{V}$	$t_{FILIN2}$	-	400	-	ns
Input filter time EN		$t_{FILEN}$	300	430	-	ns
Fault clear time after ITRIP-fault	$V_{LIN,HIN} = 0\text{V} \& 5\text{V}$ $V_{ITRIP} = 0\text{V}$	$t_{FLTCLR}$	-	4.7	-	ms
Min. deadtime between low side and high side		$DT_{PWM}$	-	1	-	$\mu\text{s}$
Deadtime of gate drive circuit		$DT_{IC}$	-	380	-	ns
IGBT Turn-on Energy (includes reverse recovery of diode)	$I_{out} = 6\text{A}$ , $V_{DC} = 300\text{V}$ $T_{vj} = 25^\circ\text{C}$ $T_{vj} = 150^\circ\text{C}$	$E_{on}$	-	145	-	$\mu\text{J}$
IGBT Turn-off Energy	$I_{out} = 6\text{A}$ , $V_{DC} = 300\text{V}$ $T_{vj} = 25^\circ\text{C}$ $T_{vj} = 150^\circ\text{C}$	$E_{off}$	-	122	-	$\mu\text{J}$
Diode recovery Energy	$I_{out} = 6\text{A}$ , $V_{DC} = 300\text{V}$ $T_{vj} = 25^\circ\text{C}$ $T_{vj} = 150^\circ\text{C}$	$E_{rec}$	-	31	-	$\mu\text{J}$
			-	81	-	

### Integrated Components

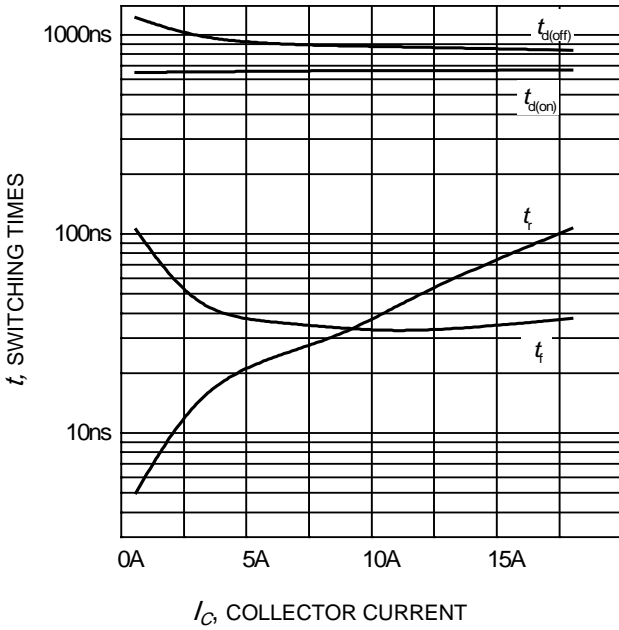
Description	Condition	Symbol <sup>1</sup>	Value			Unit
			min	typ	max	
Resistor (0.25 W)		Rbs	-	10	-	Ω
Resistor		R	-	24	-	kΩ
Resistor	$T_{NTC} = 25^{\circ}\text{C}$	RTS	-	100	-	kΩ
B-Constant of NTC (Negative Temperature Coefficient)	$T_{NTC} = 25^{\circ}\text{C}$	B25	-	4250	-	K
Bootstrap diode forward voltage	$I_{FDbs} = 100\text{mA}$	$V_{FDbs}$	-	1.9	2.05	V
Capacitor		C1	-	100	-	nF
Capacitor		C2	-	2.2	-	
Bootstrap Capacitor		$CbsH_x$	-	100	-	

### Circuit of a Typical Application

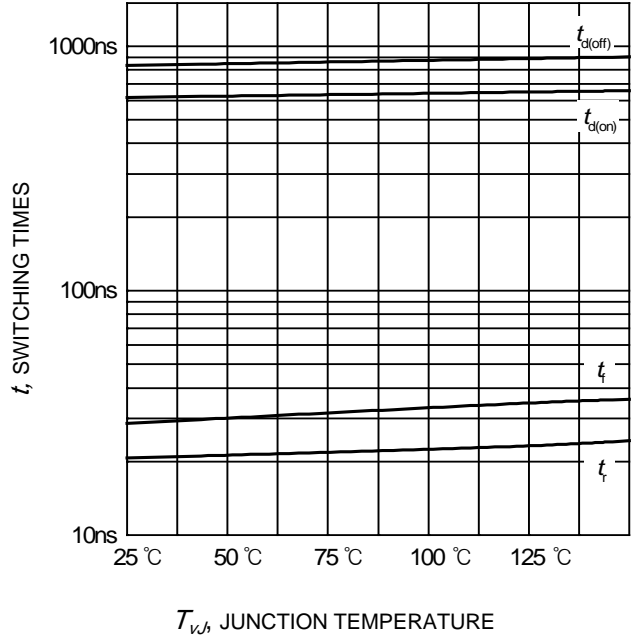


<sup>1</sup> Symbols according to Figure 1

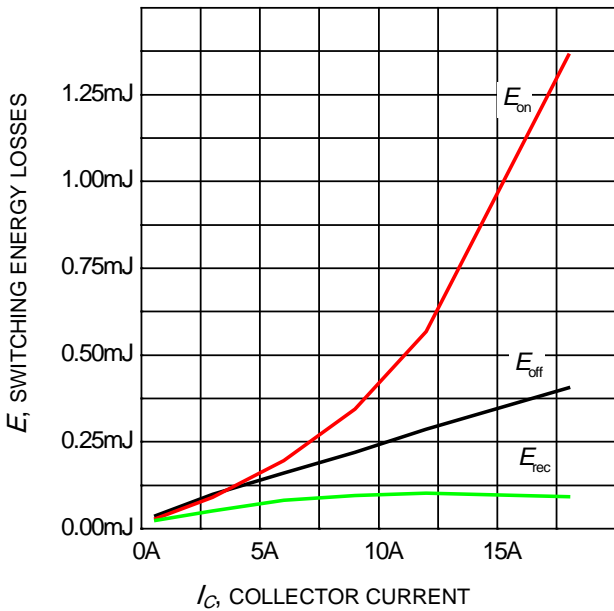
**Characteristics**



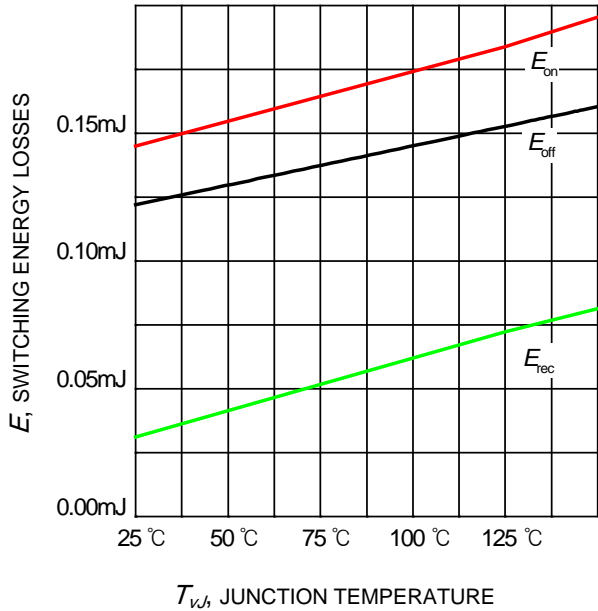
**Figure 5. Typical switching times as a function of collector current**  
(inductive load,  $T_J=150^{\circ}\text{C}$ ,  $V_{CE} = 300\text{V}$ ,  $V_{DD} = 15\text{V}$   
Dynamic test circuit in Figure A)



**Figure 6. Typical switching times as a function of junction temperature**  
(inductive load,  $V_{DD} = 15\text{V}$ ,  $V_{CE} = 300\text{V}$ ,  $I_C = 6\text{A}$   
Dynamic test circuit in Figure A)



**Figure 7. Typical switching energy losses as a function of collector current**  
(inductive load,  $T_J = 150^{\circ}\text{C}$ ,  $V_{CE} = 300\text{V}$ ,  $V_{DD} = 15\text{V}$   
Dynamic test circuit in Figure A)



**Figure 8. Typical switching energy losses as a function of junction temperature**  
(inductive load,  $V_{CE} = 300\text{V}$ ,  $V_{DD} = 15\text{V}$ ,  $I_C = 6\text{A}$   
Dynamic test circuit in Figure A)

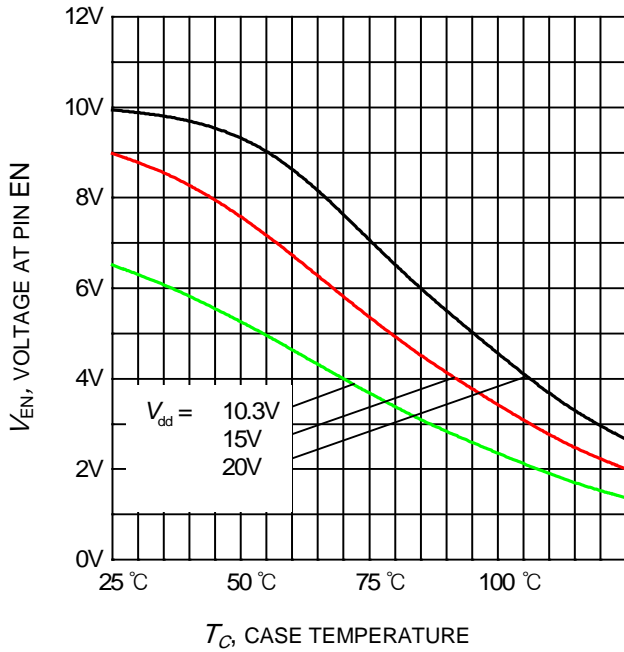


Figure 9. Typical voltage at pin EN as a function of case temperature

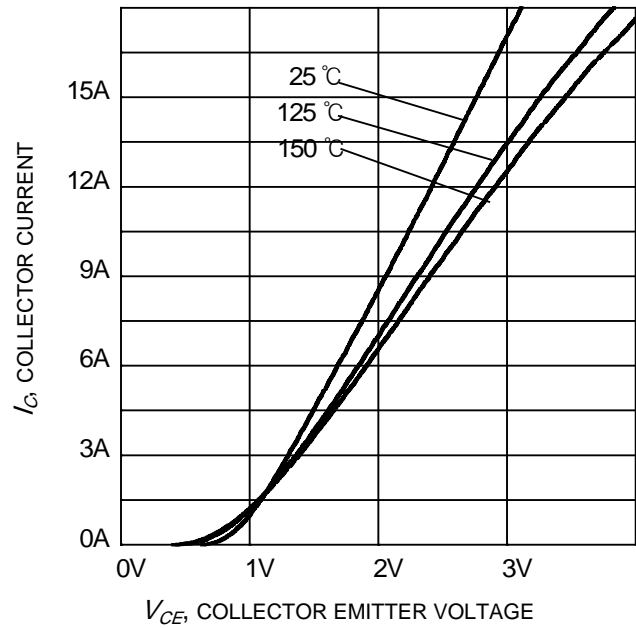


Figure 10. Typical output characteristic of IGBT as a function of collector emitter voltage ( $V_{DD} = 15V$ )

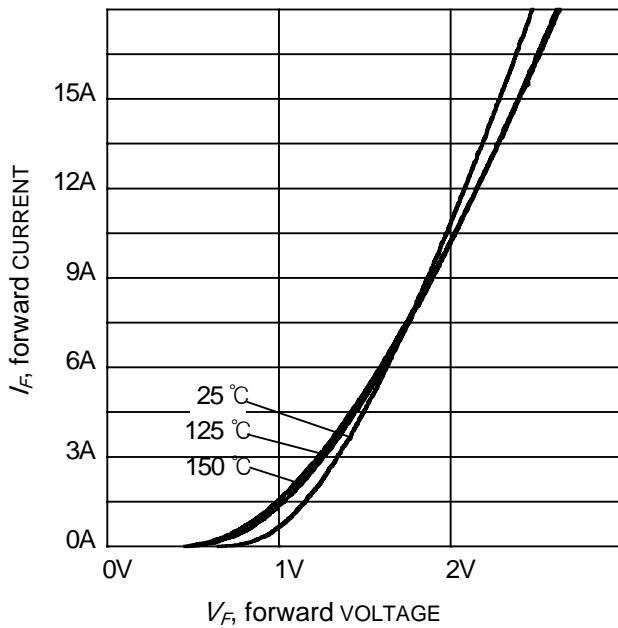


Figure 11. Typical diode forward current as a function of forward voltage

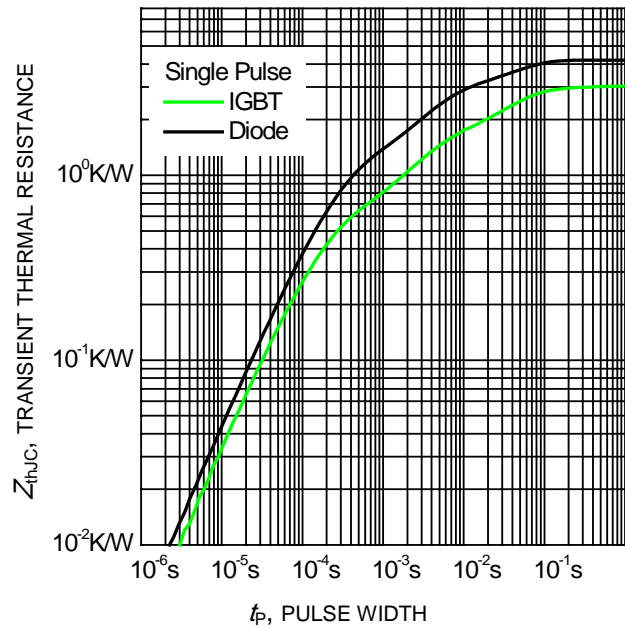
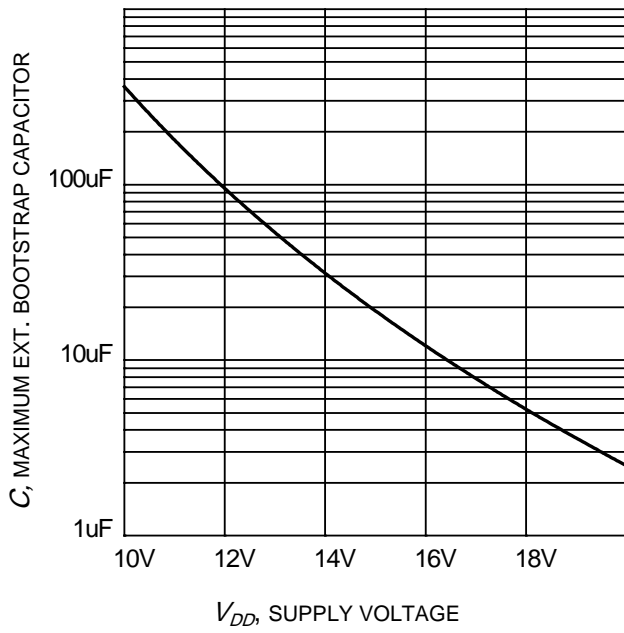
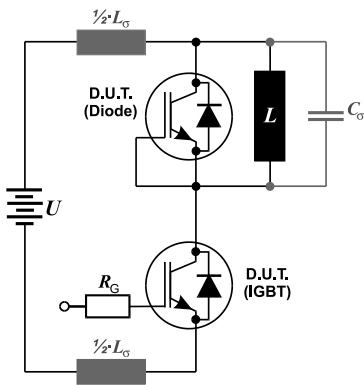


Figure 12. Transient thermal impedance as a function of pulse width ( $D = t_p / T$ )

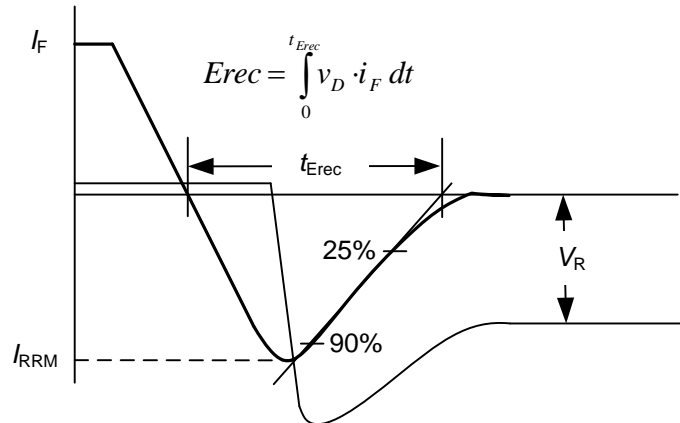


**Figure 13. Maximum ext. bootstrap capacitor as a function of supply voltage  $V_{DD}$**   
( $T_J=25^\circ\text{C}$ , single capacitor charging)

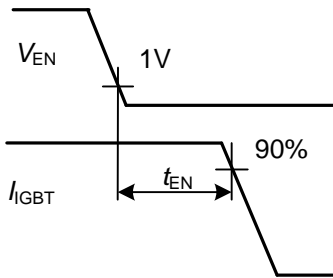
**Test Circuits and Parameter Definition**



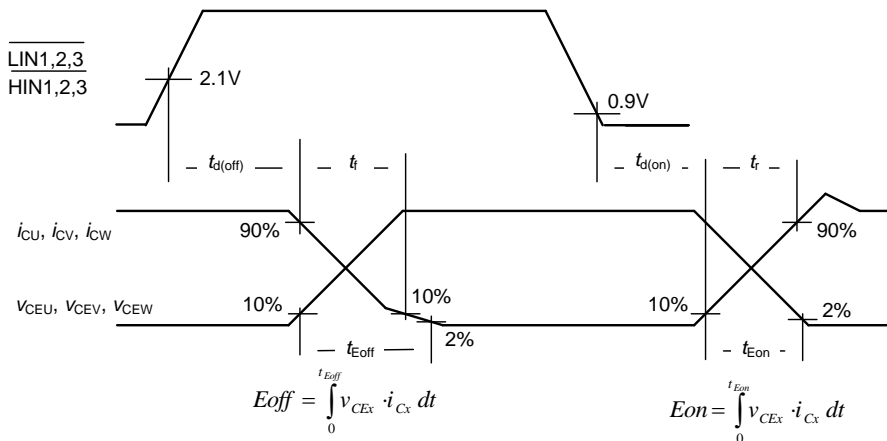
**Figure A: Dynamic test circuit**  
Leakage inductance  $L_\sigma = 180\text{nH}$   
Stray capacitance  $C_\sigma = 39\text{pF}$



**Figure B: Definition of diodes switching characteristics**

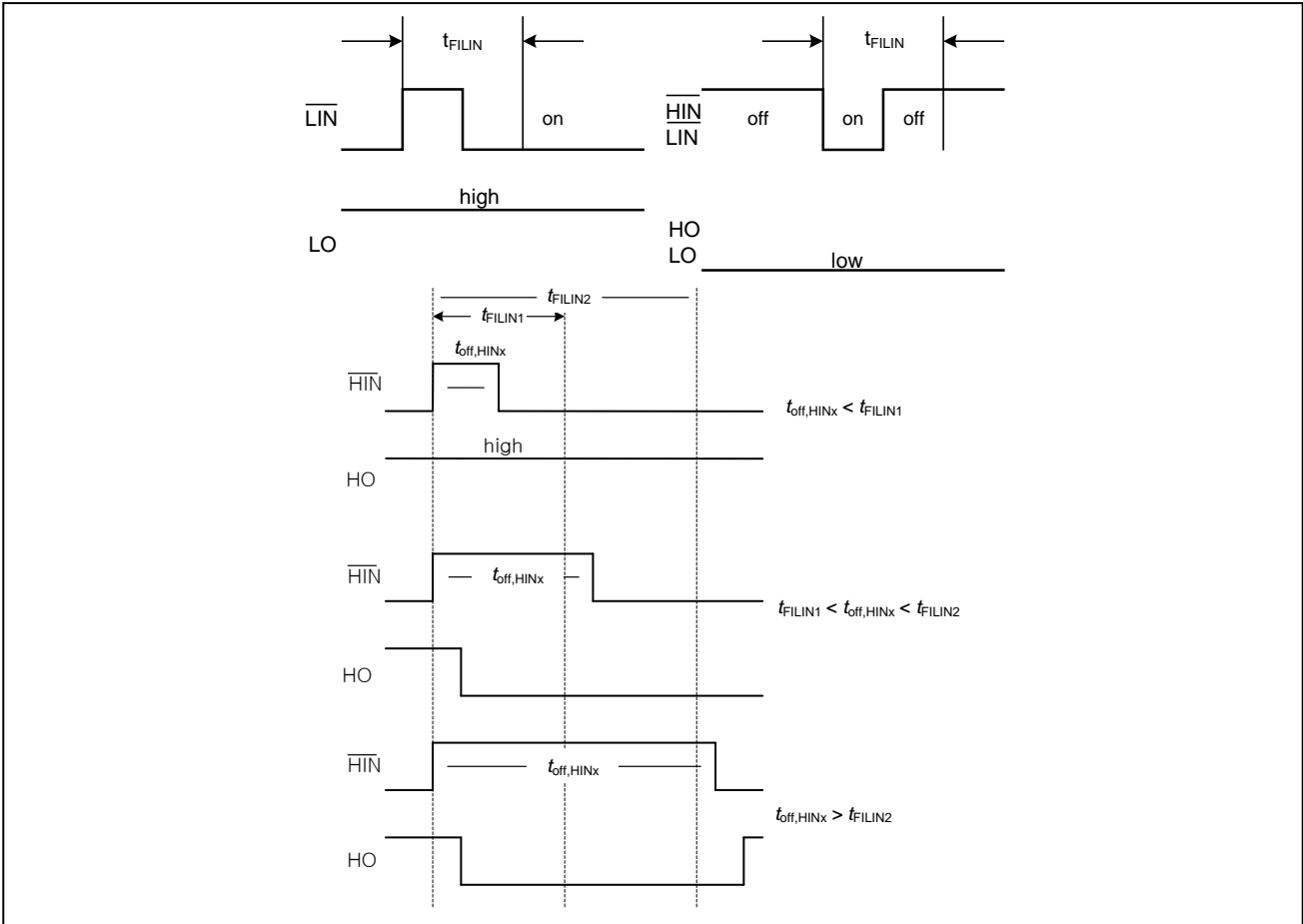


**Figure C: Definition of Enable propagation delay**



**Figure D: Switching times definition and switching energy definition**

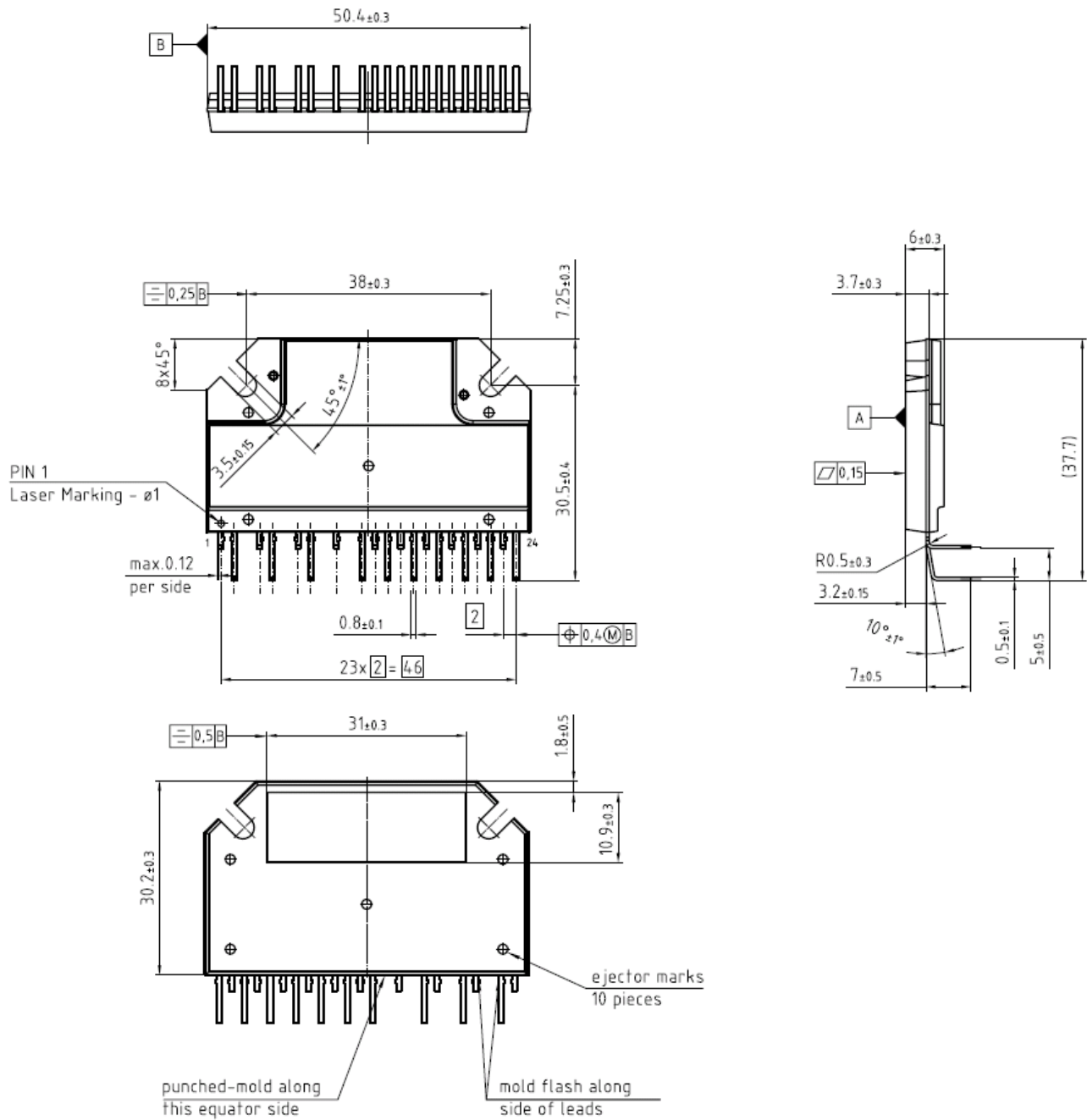




**Figure E: Short Pulse suppression**



**Package Outline IKCS12F60AC**



**Package Data**

Description	Condition	Symbol	Value			Unit
			min	typ	max	
Weight		$m_p$	-	17	-	g

Note: There may occur discolorations on the copper surface without any effect of the thermal properties.

# Mouser Electronics

Authorized Distributor

Click to View Pricing, Inventory, Delivery & Lifecycle Information:

[Infineon:](#)

[IKCS12F60AA](#)